

REGALBOARD®

Woodlike Vintage Composite Decking



Regalboard® Cladding



What is Regalboard Cladding?

An innovational cladding system with both stunning and unique surface looks and durable function properties.

Stabilizing Sheet
to make the board stiffer with
less expansion and contraction rate

Cellular Core
to reduce weight

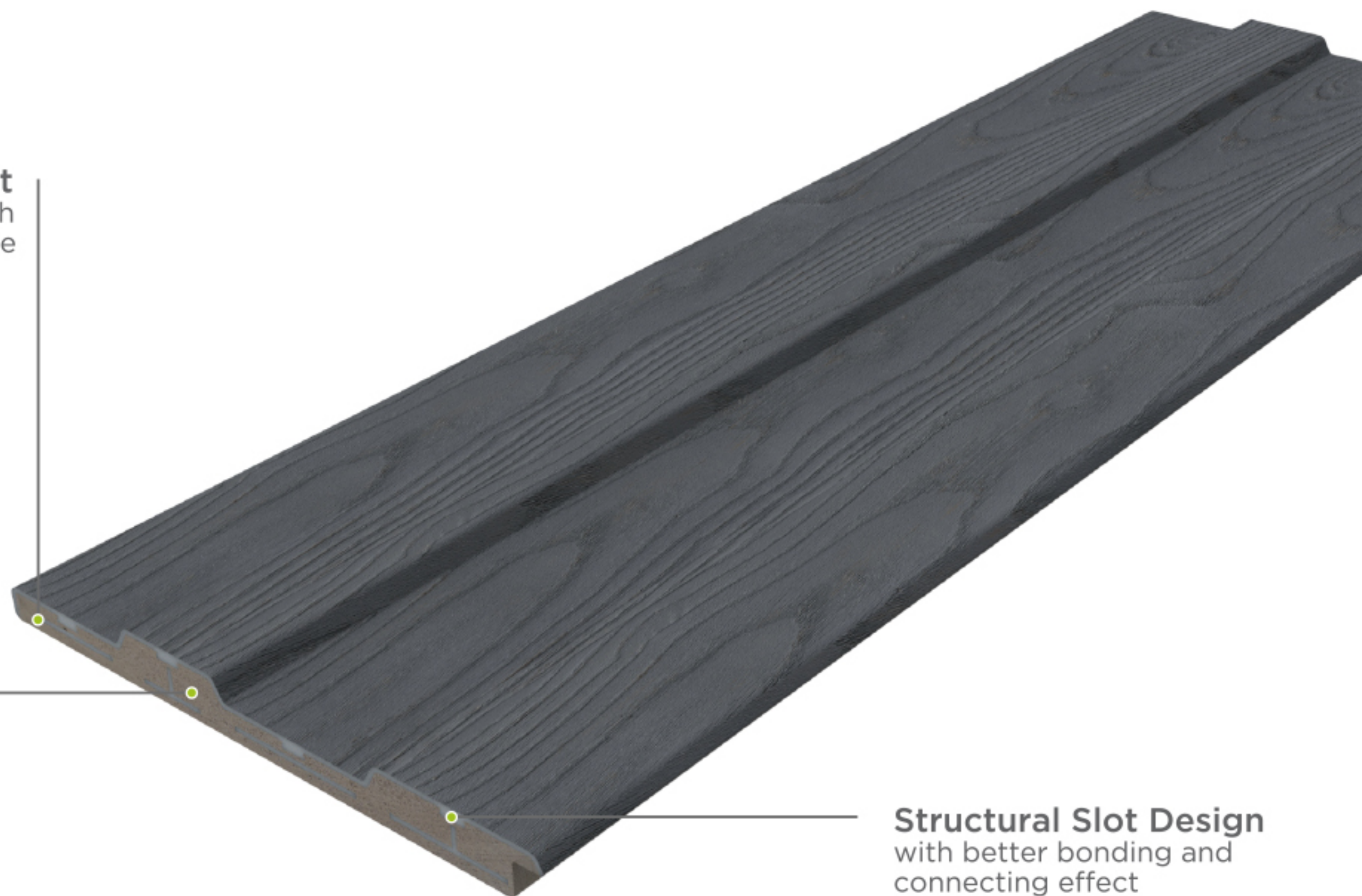

Structural Slot Design
with better bonding and
connecting effect



Horizontal Installation

ADVANTAGES OF REGALBOARD CLADDING



DISTINCTIVE GRAIN PATTERN

Grain moulded from real wood species



RELIABLE DURABILITY

Reinforcement technology tremendously optimised the board mechanical performance



LOW-MAINTENANCE

The look of timber, without the constant upkeep



EASY & EFFICIENT INSTALLATION

No clip needed, screw invisible solution



ROT & CRACK RESISTANT

Free of plant fibers, to avoid moisture, termites, mould, fungi



MANUFACTURED WITH SOLAR ENERGY

Art&Craft is fully committed to offering you a product that's green from start to finish



Thanks to the light weight design and ultra low expansion and contraction rate characteristic, Regalboard cladding can be with direct top fixing solution, but without various clips, predrilling and etc, which will offer you a really easy, fast, false and fatigue free installation wall panel.





Vertical Installation



Regalboard cladding, a real timber like panel with vivid and lifelike grain pattern simulated.



COLOR

Inspired by natural timber tones, Regalboard is able to carry out delicate deckings with both natural grain appearance and vivid color options. Up to your preference, Regalboard is always ready to offer distinctive customized designs with great pattern and color flexibility.

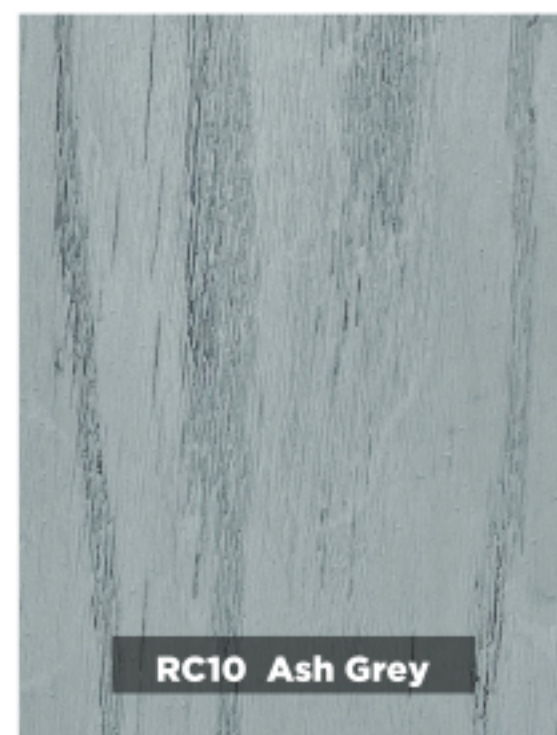
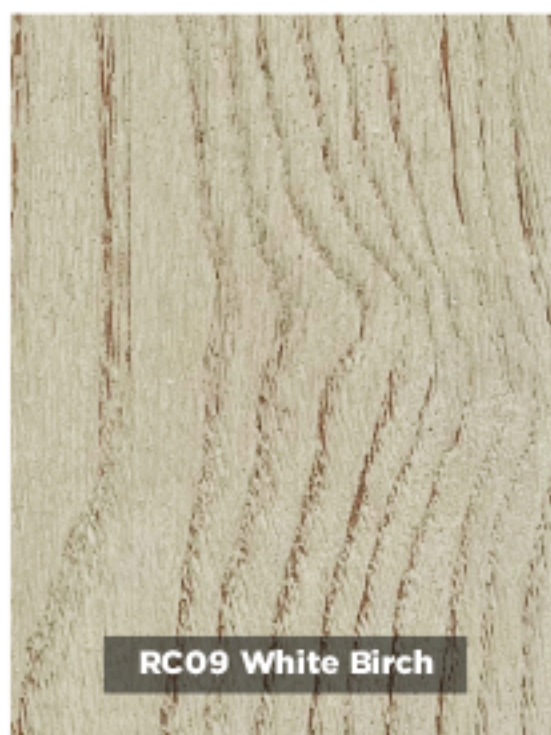
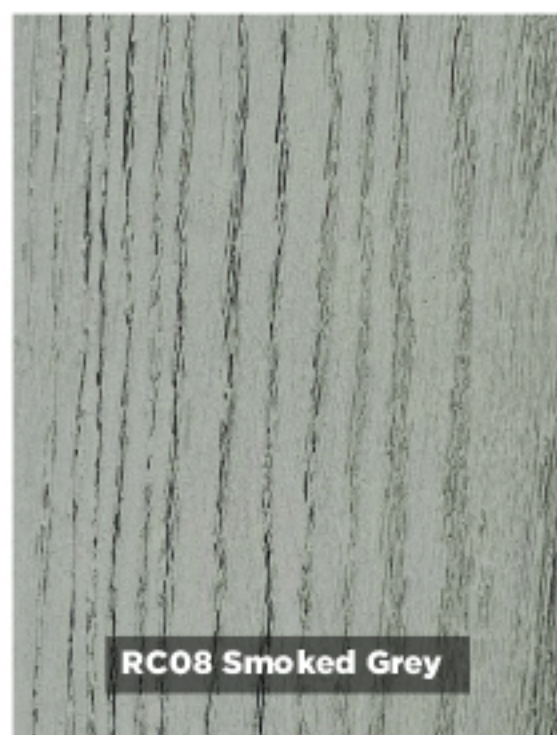
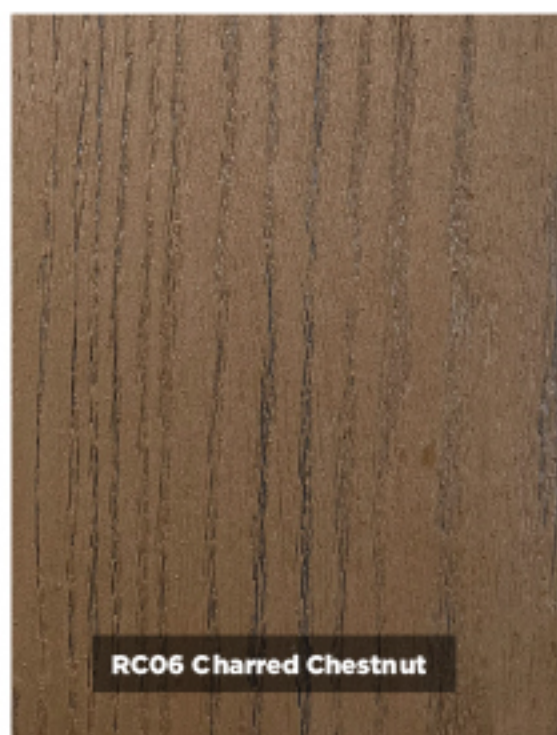
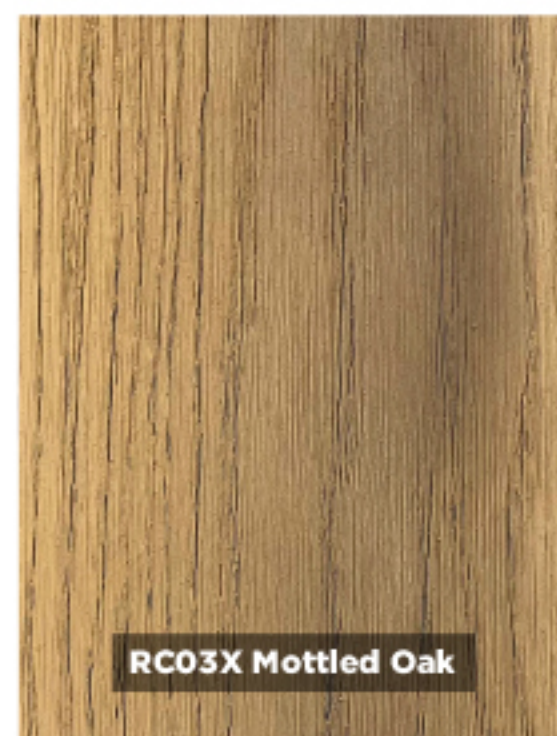
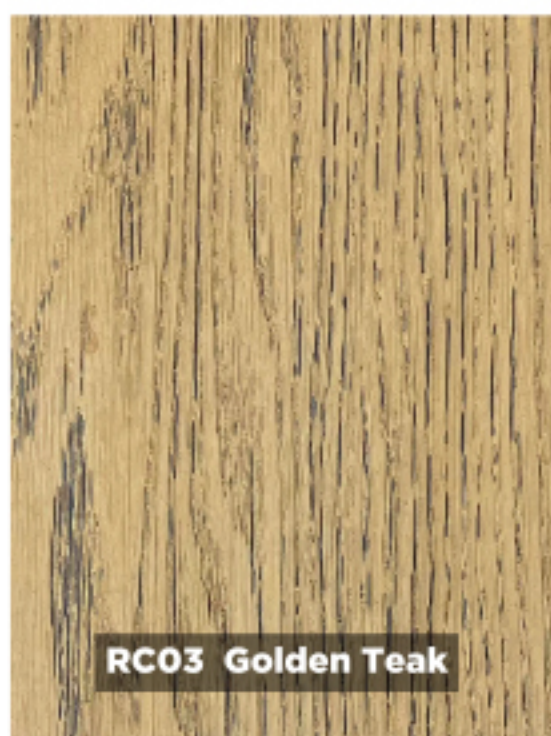





Fixing Screw

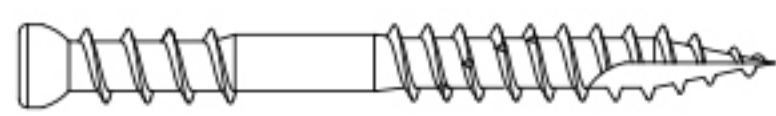

M3.5

SS304 material top fixing screw, for structural points fixing to ensure firm fastening effect

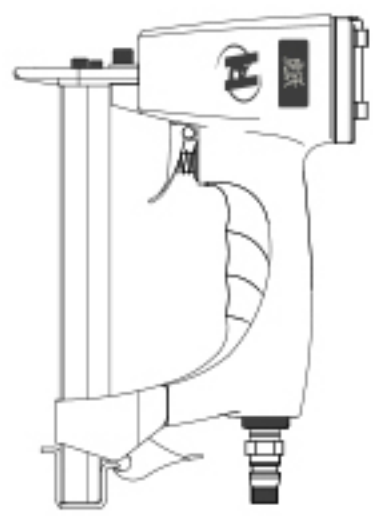

Nail Gun

Brads nail may be taken for supplemental fixing solution to achieve high efficiency

Regalboard Profiles



Un-milled cladding board
STZQJAZ09 179.1x15.5mm



Milled cladding board
STZQJAZ09 179.1x15.5mm

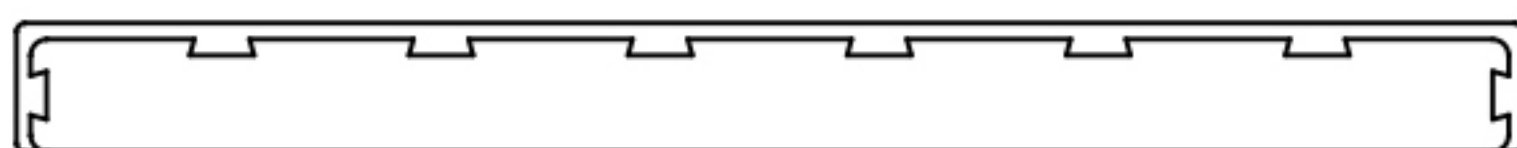

Trim board STJAZ07 187.5x16mm



Edge board STJAZ08 48x22mm



Regalboard cladding vertical installation

STEP 1

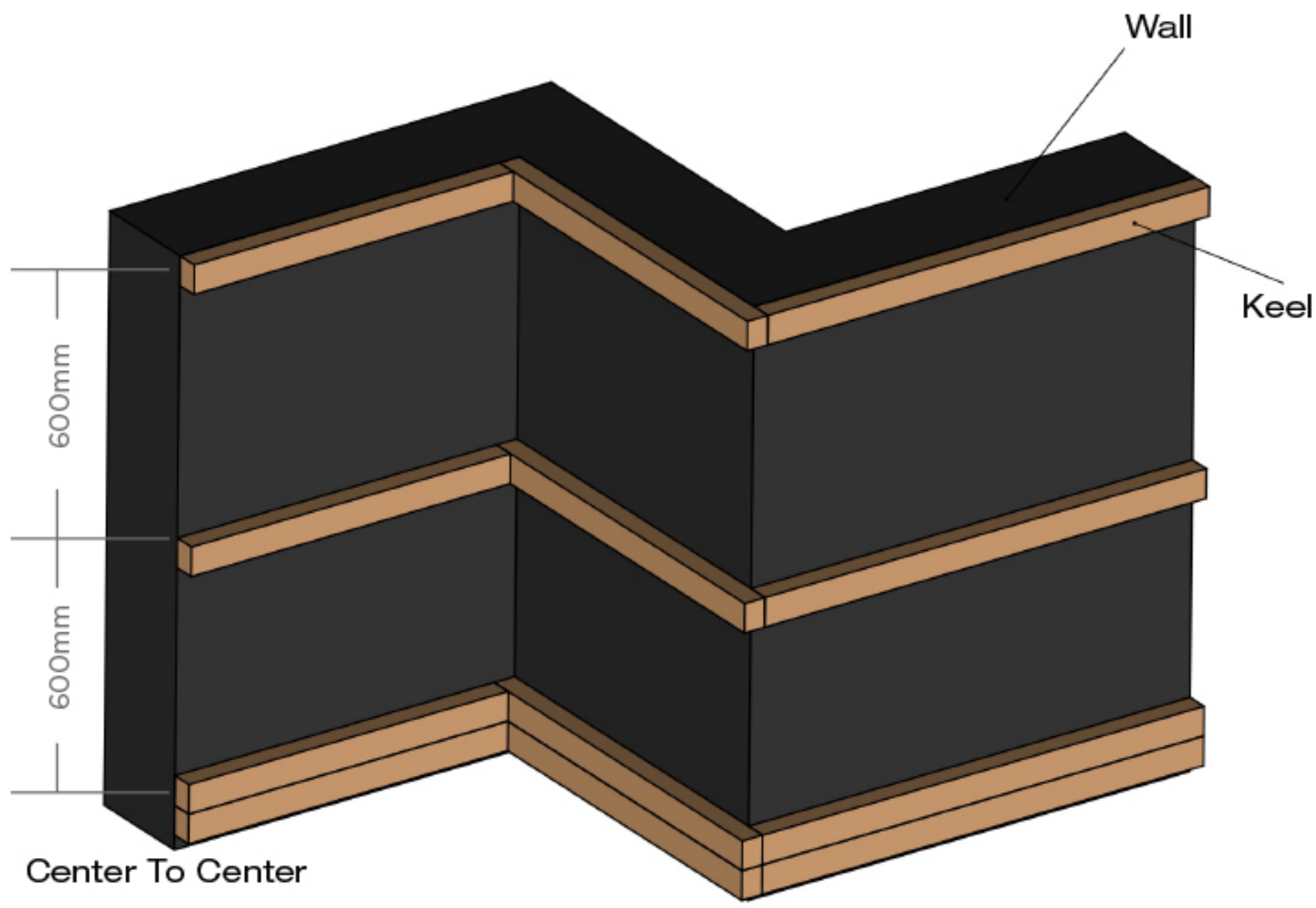

STEP 2

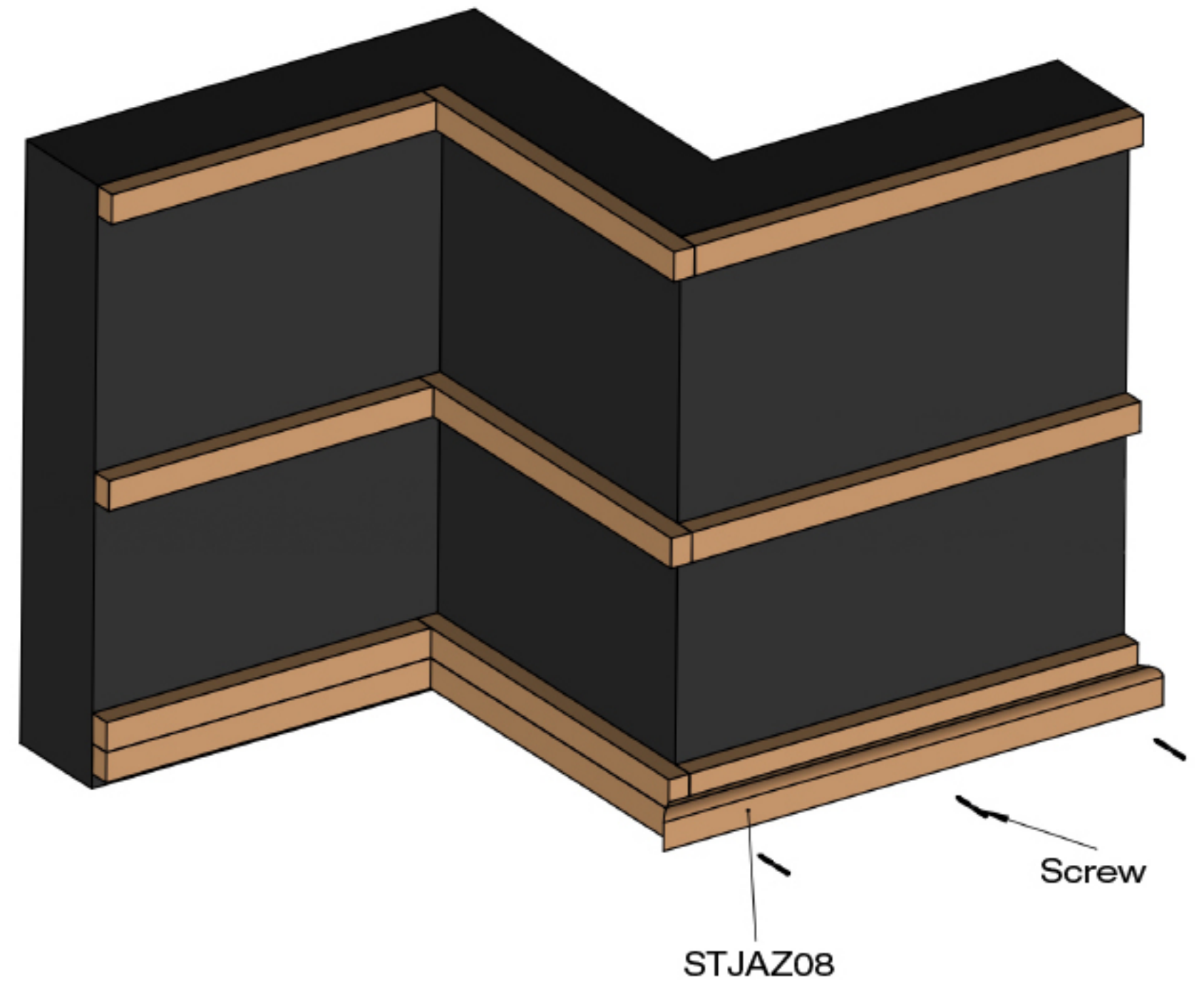

STEP 3

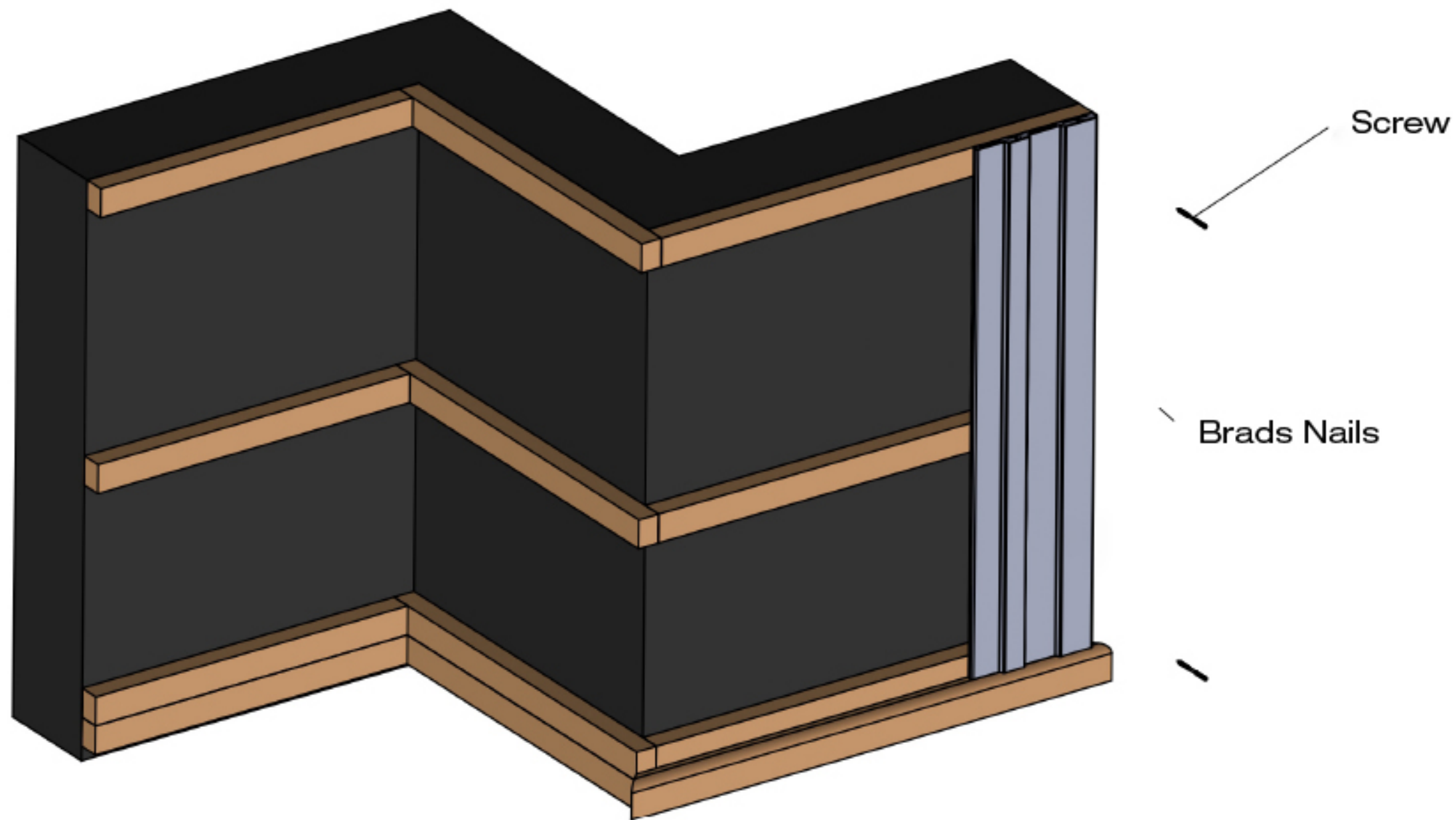

STEP 4

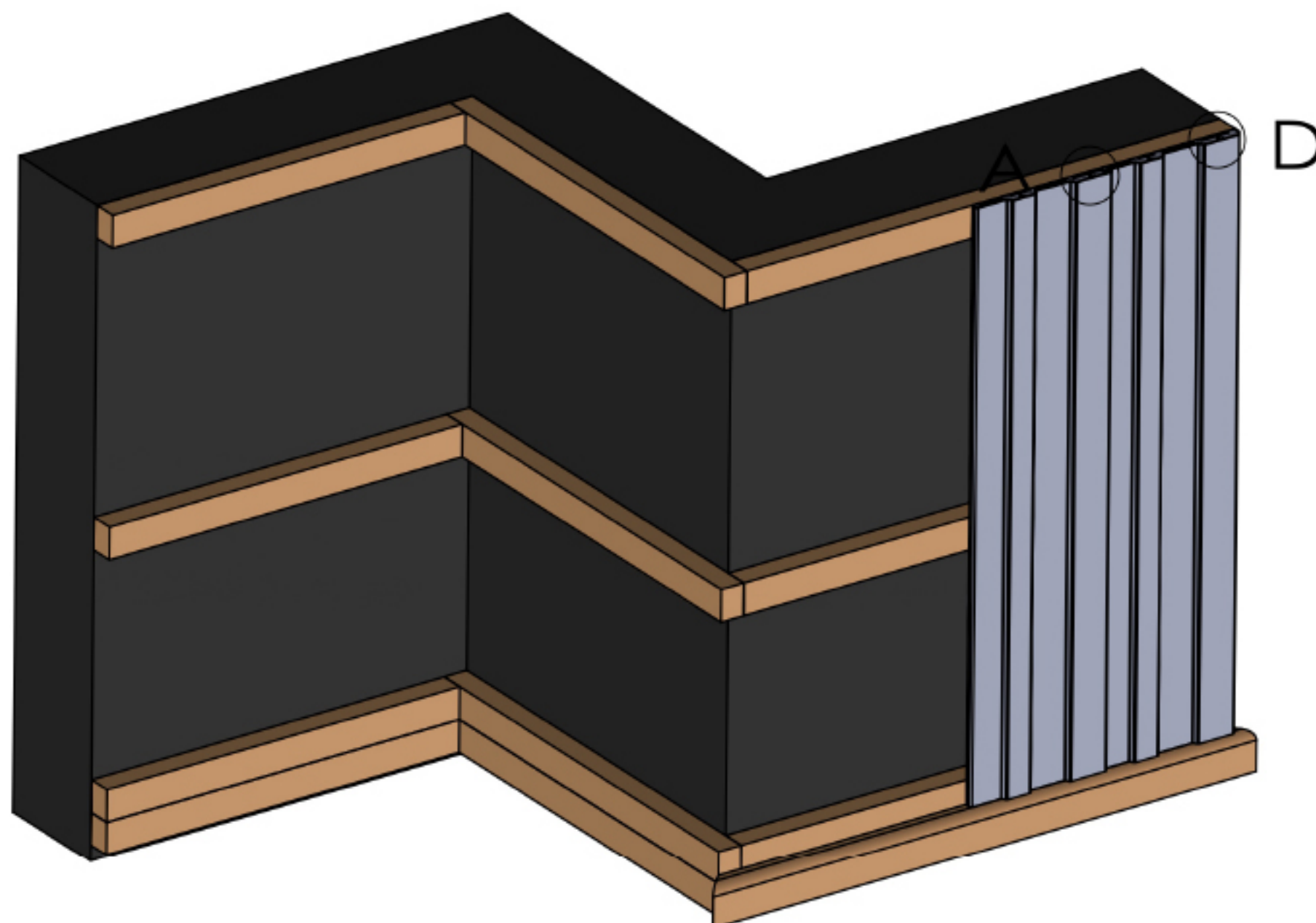

The STZQJAZ09 is easy to install with overlap tongue and groove design

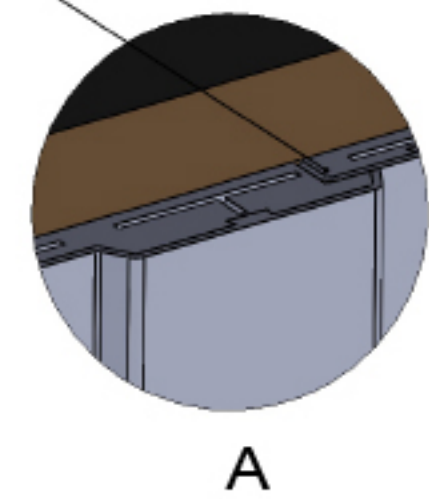

It recommended to keep the first cladding board edge un-milled

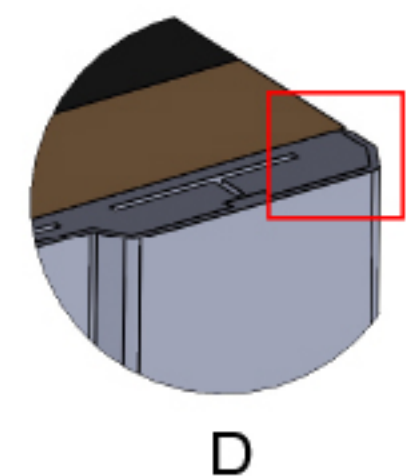

STEP 5

Install the remaining STZQJAZ09 cladding in turn, fix them with screws, if need cut the last but one board excess part at the external corner, and install STJAZ08 edge board on top as frame.

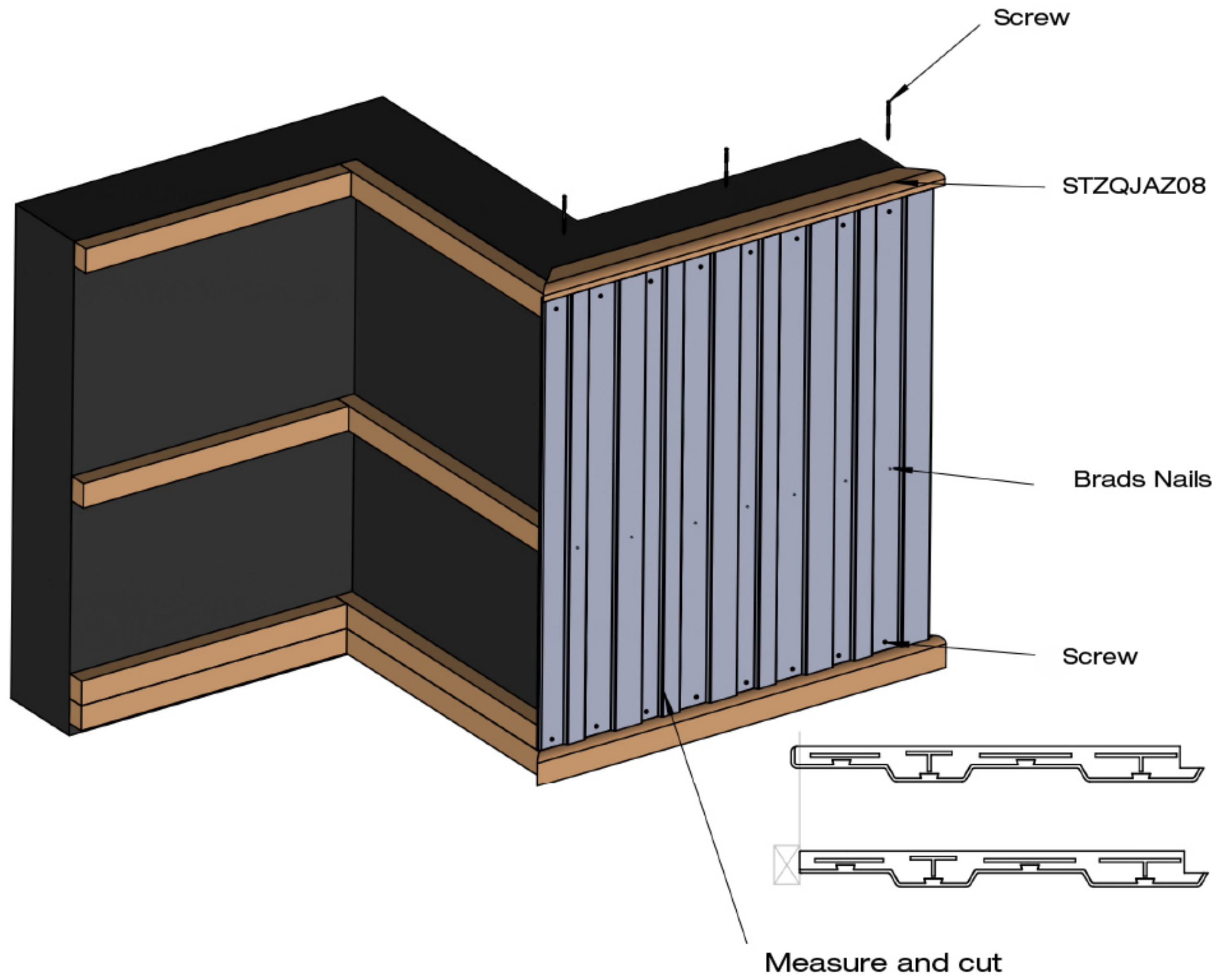

STEP 6

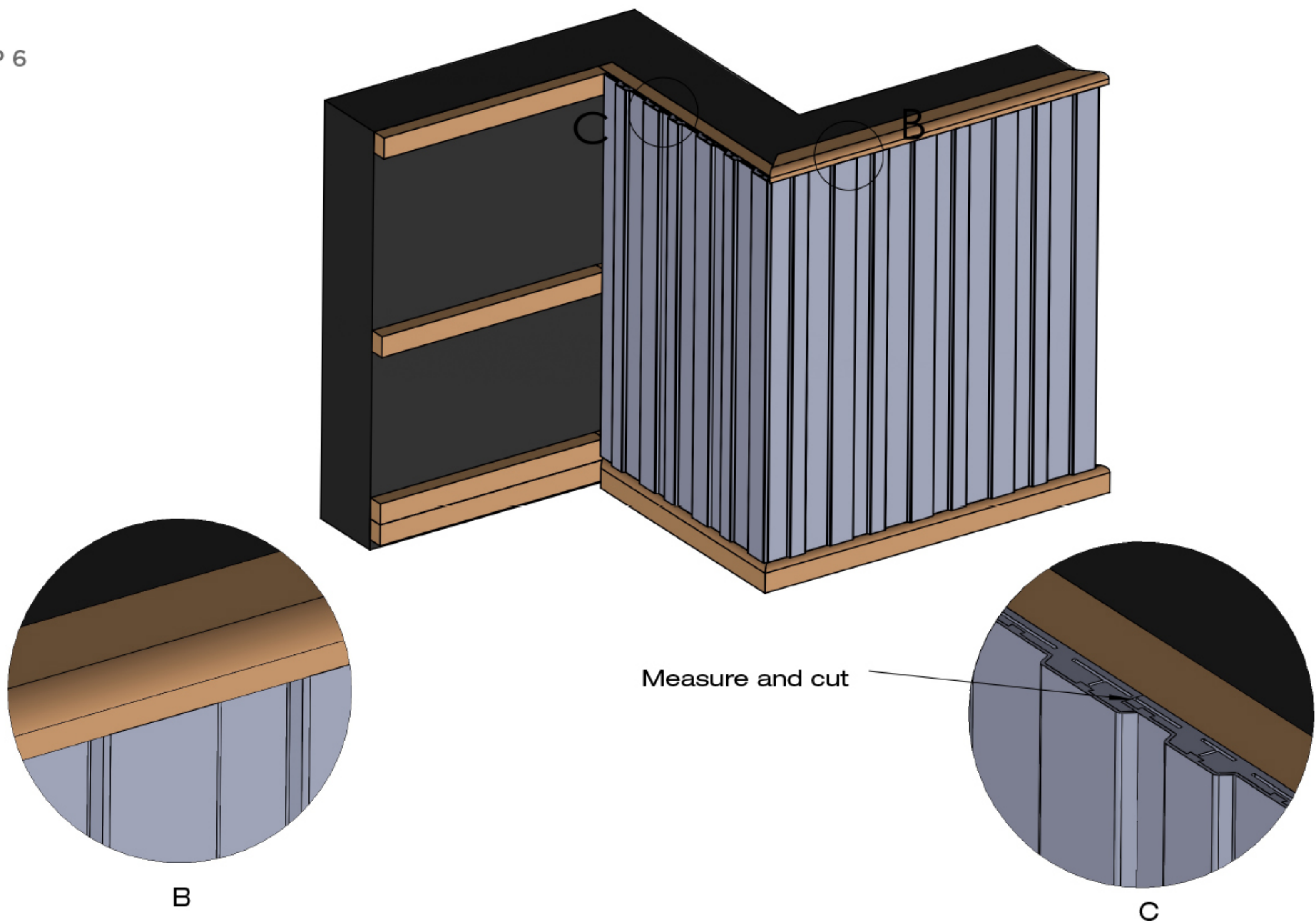

STEP 7

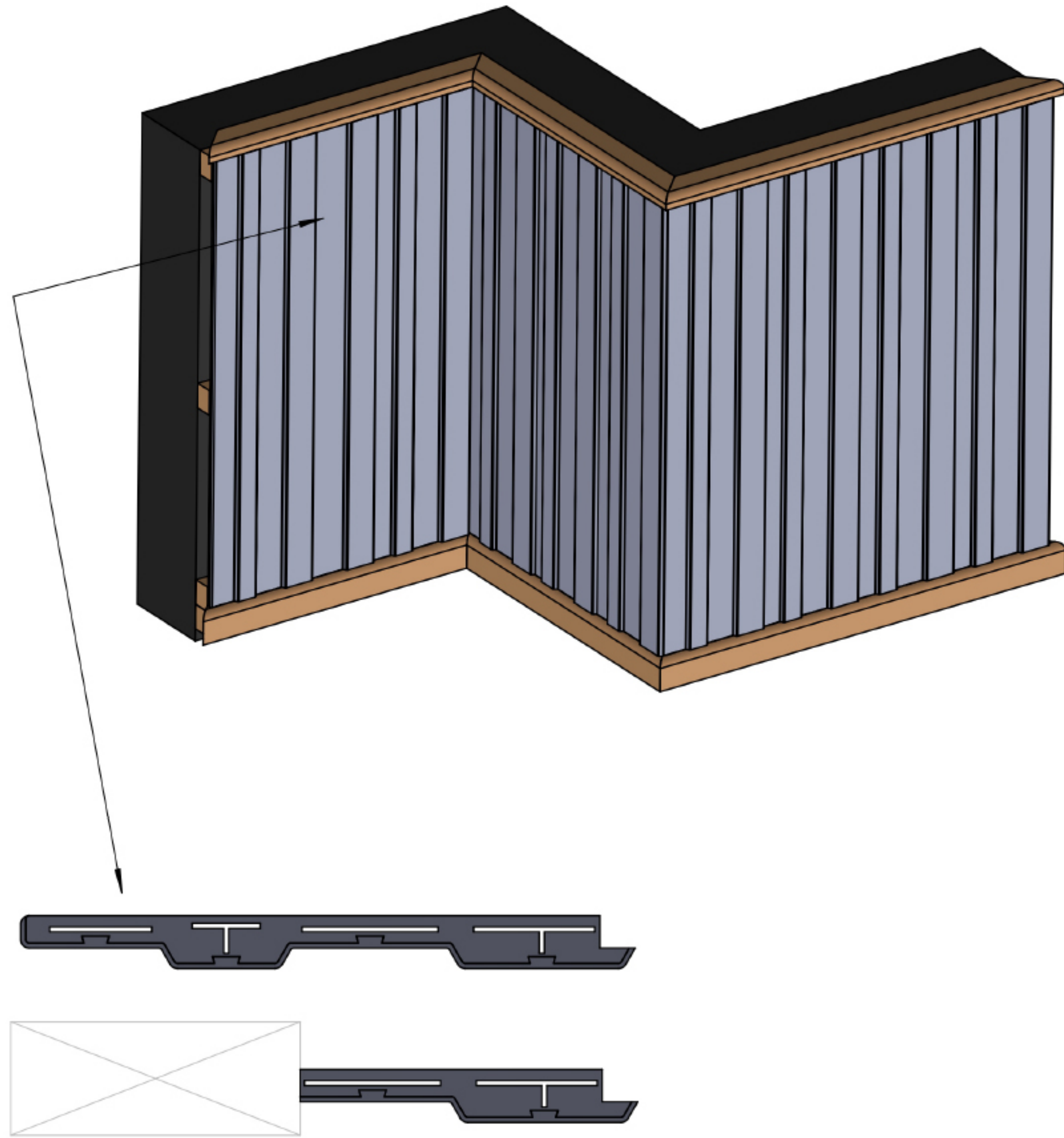

Measure and cut off the excess part of the last but one board

STEP 8

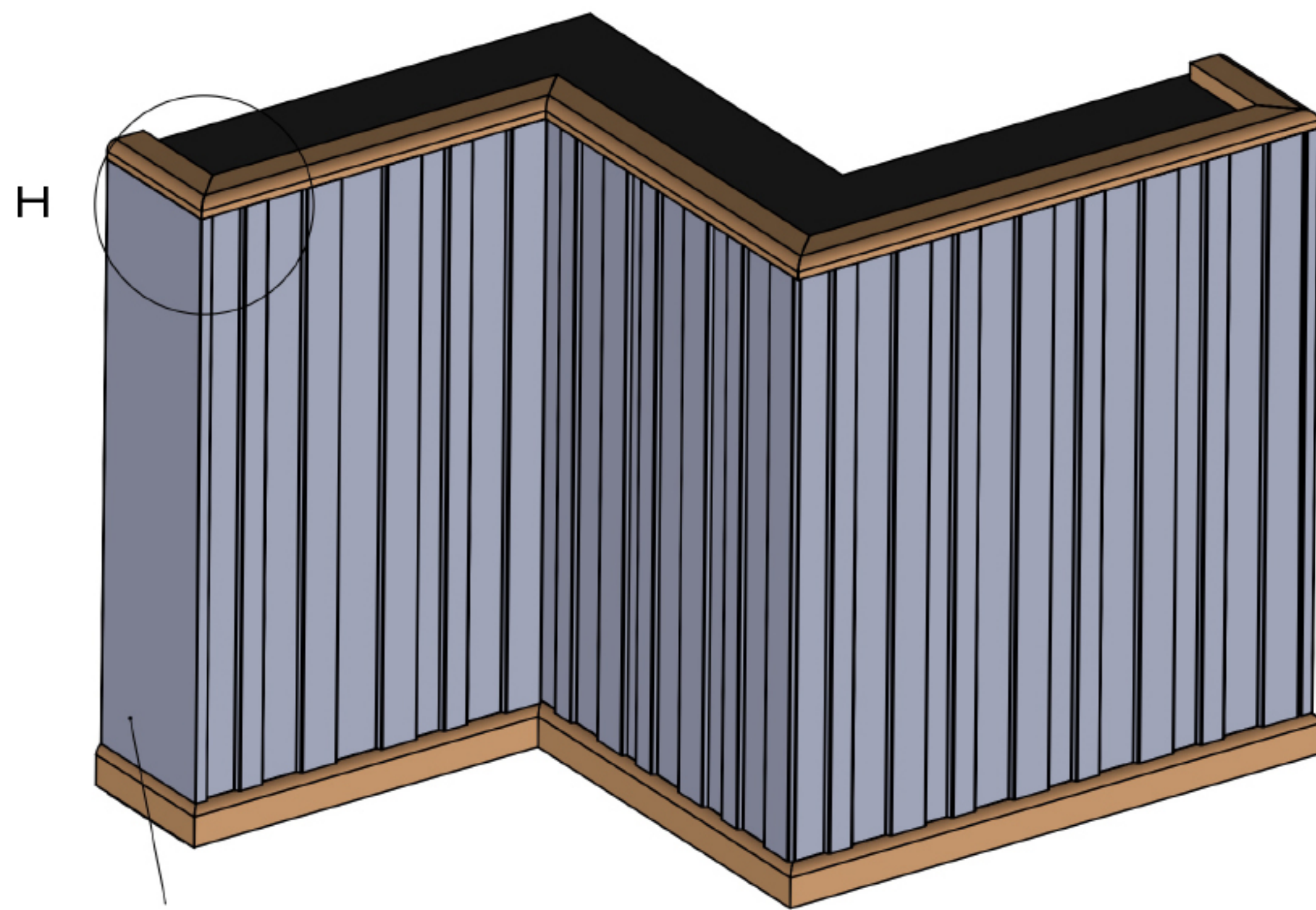

STZQJAZ07
Frame the sides with
trim board STJAZ07

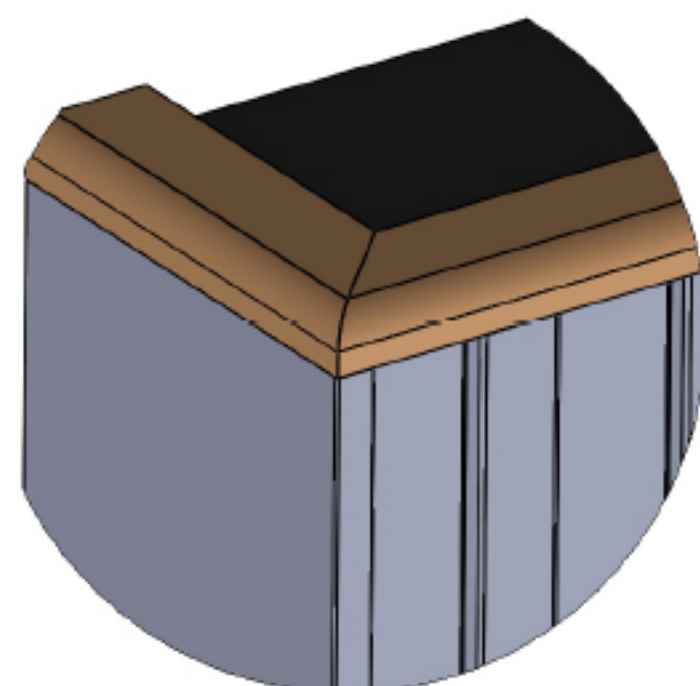

H



Regalboard cladding horizontal installation

STEP 1

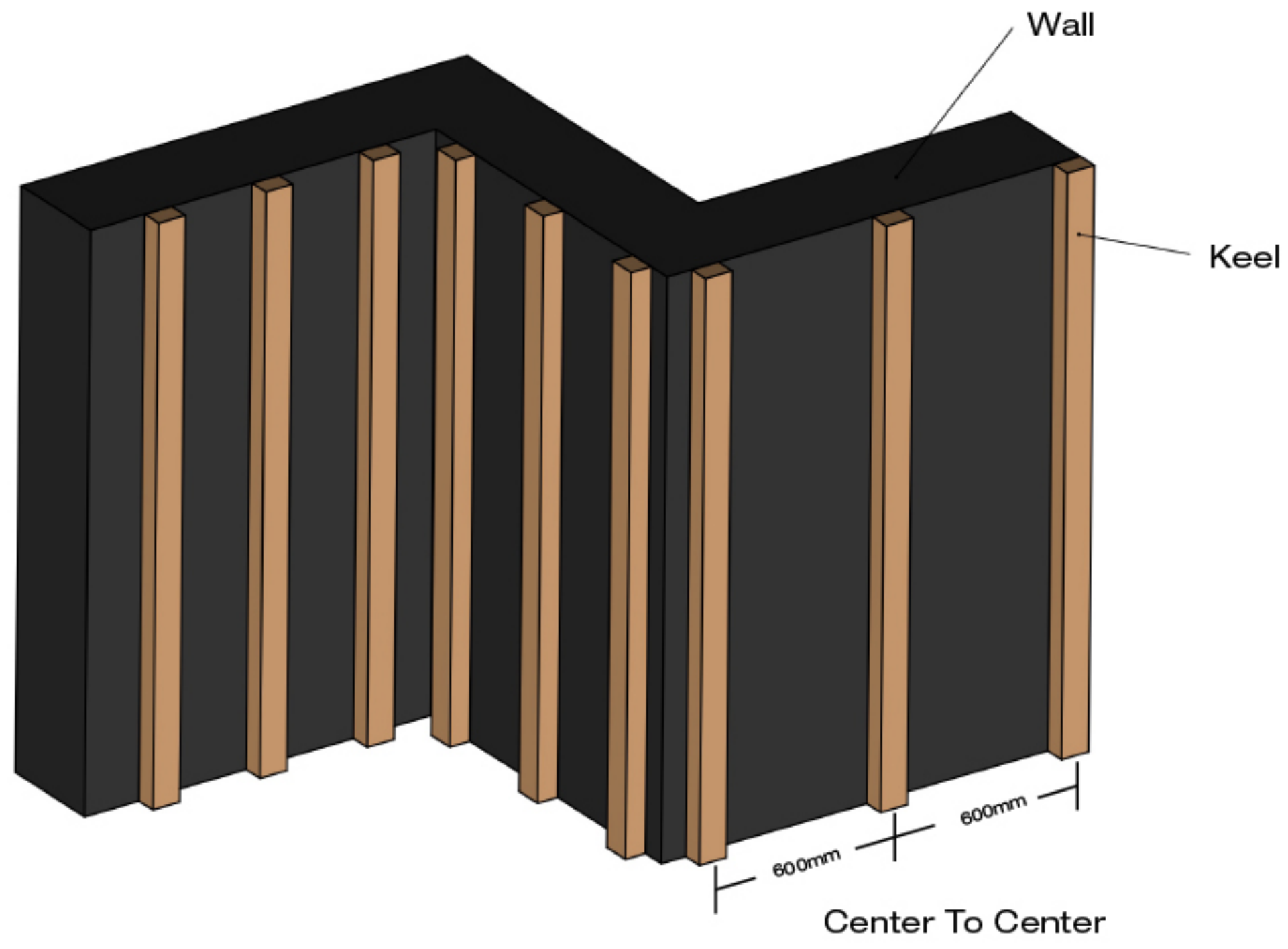

STEP 2

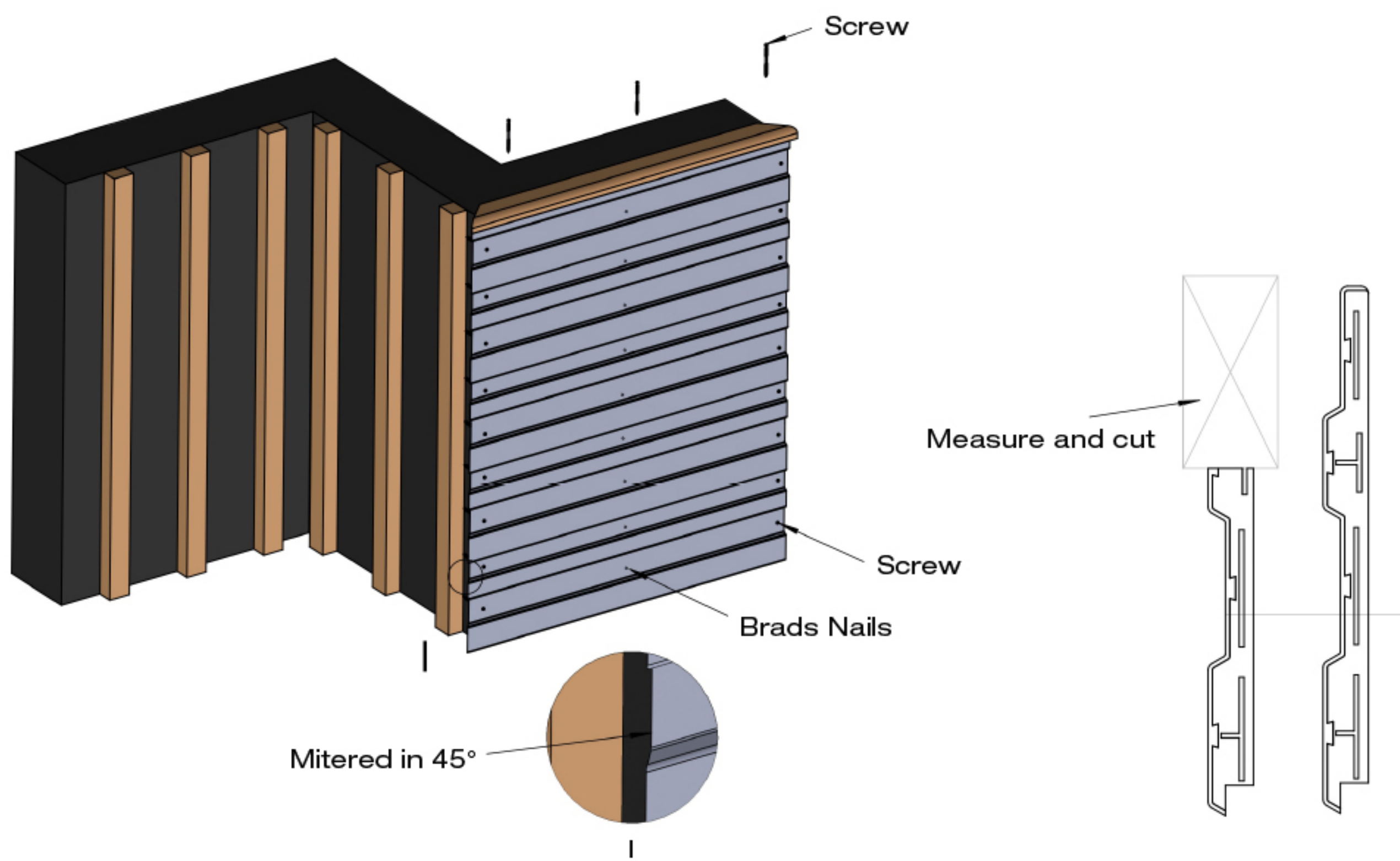

STEP 3

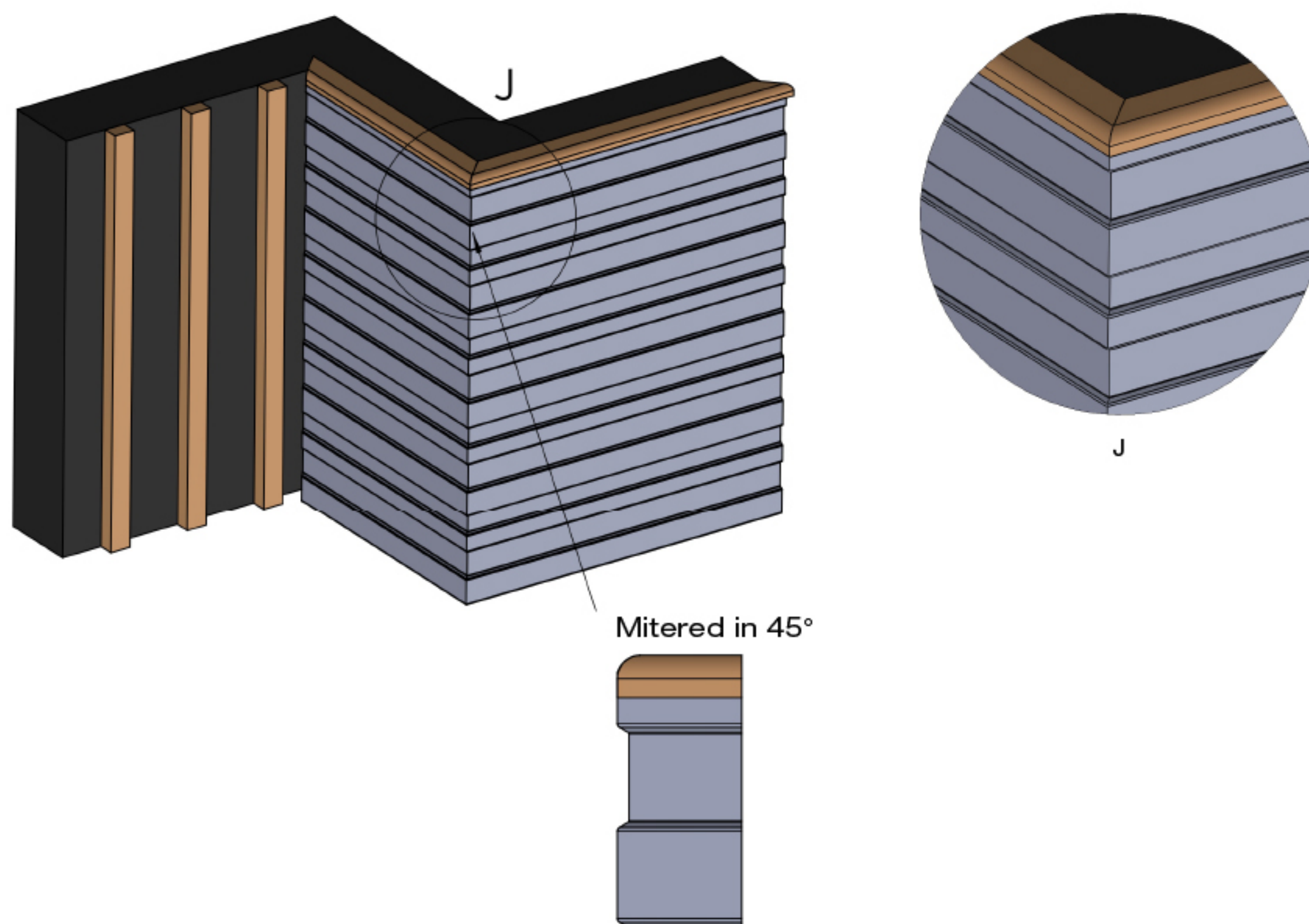

STEP 4

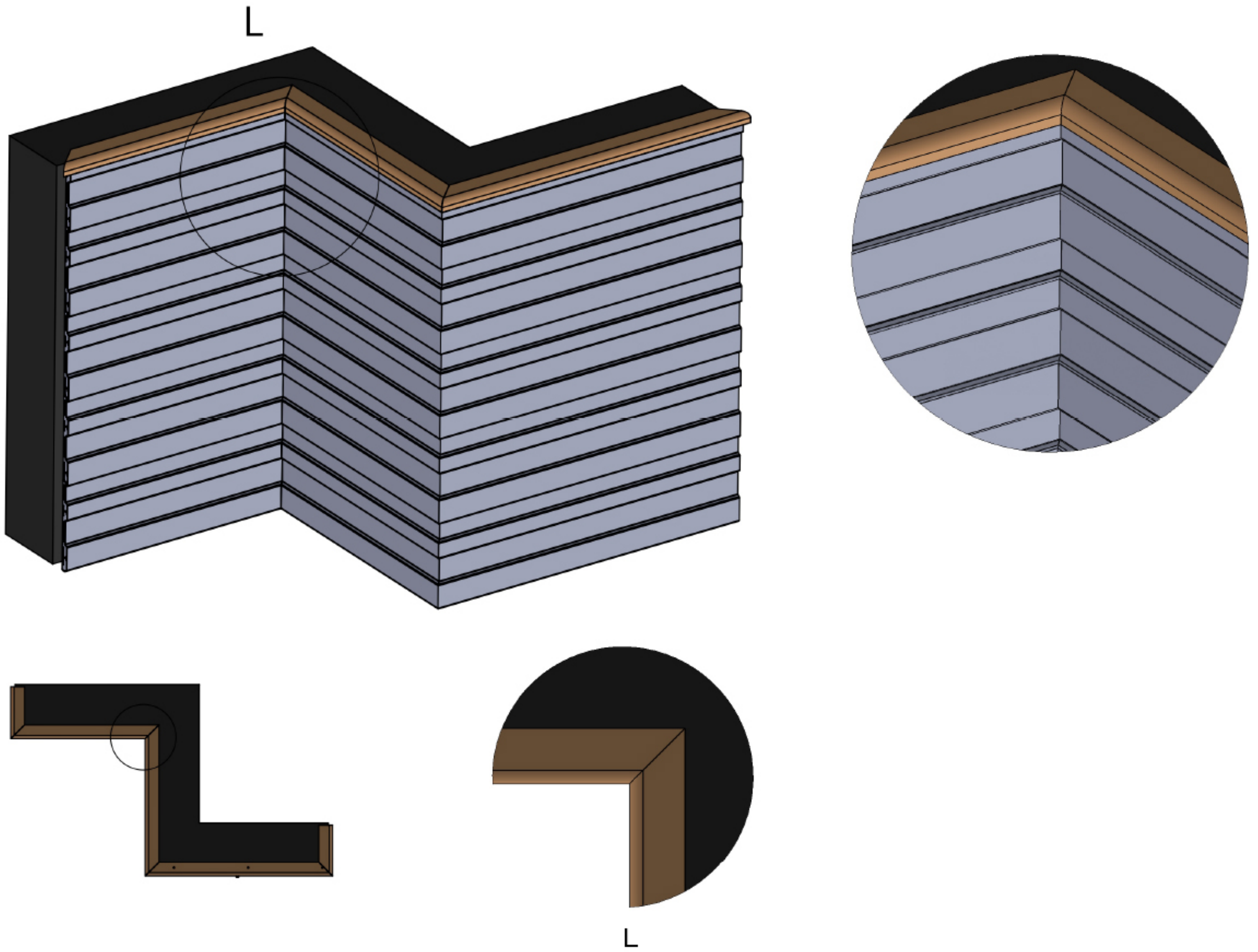

STEP 5

Frame the sides with Regalboard trim board STJAZ07

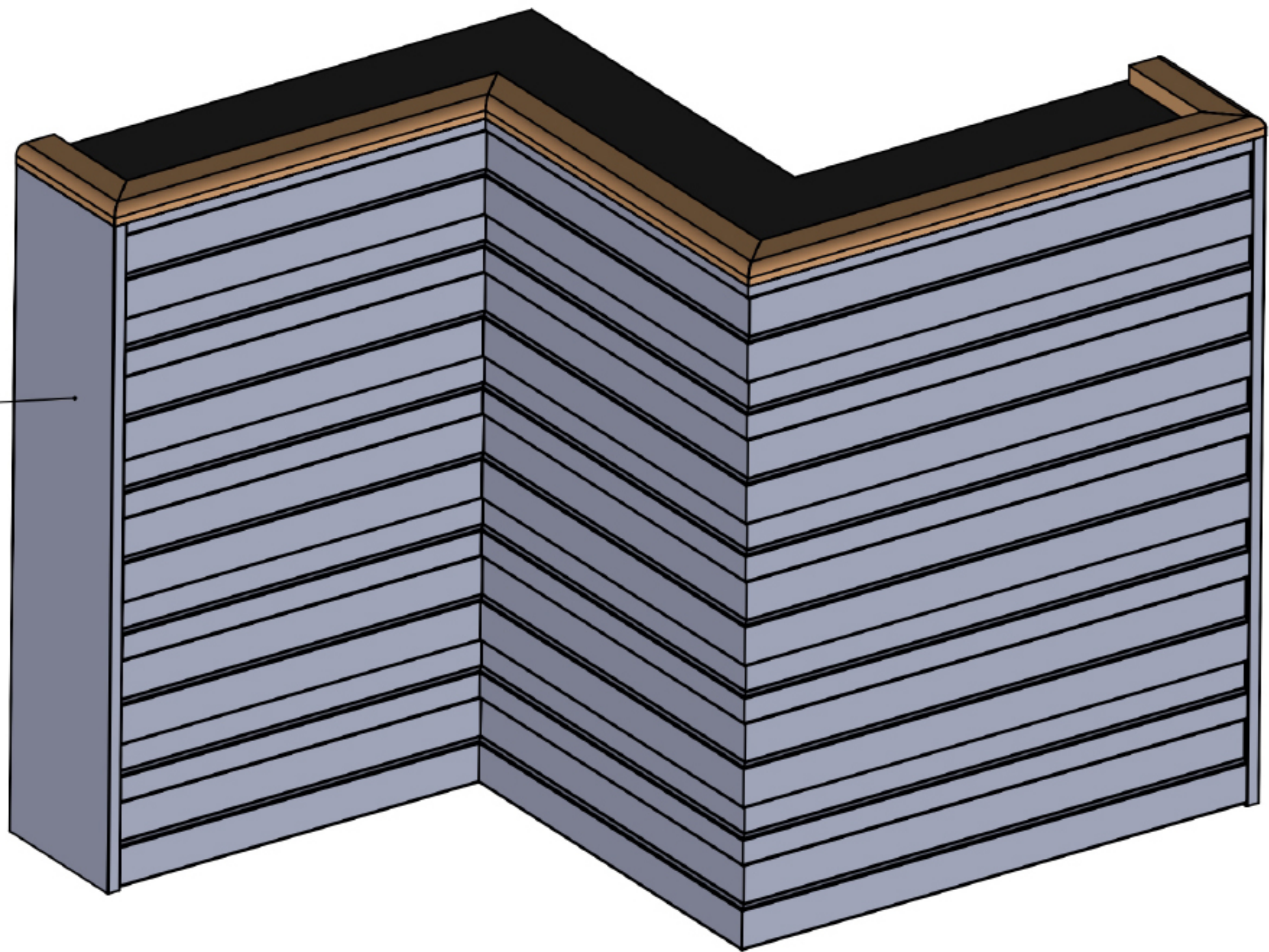



REGAL BOARD[®]
Woodlike Vintage Composite Decking

www.sentaiwpc.net